

Name: _____	Date: _____	Event: _____
City: _____	State: _____	
Track: _____		
Track Conditions: <input type="checkbox"/> Indoor <input type="checkbox"/> Tight <input type="checkbox"/> Smooth <input type="checkbox"/> Hard Packed <input type="checkbox"/> Blue Groove <input type="checkbox"/> Wet <input type="checkbox"/> Grass <input type="checkbox"/> Low Bite <input type="checkbox"/> High Bite <input type="checkbox"/> Outdoor <input type="checkbox"/> Open <input type="checkbox"/> Rough <input type="checkbox"/> Loose/Loamy <input type="checkbox"/> Dry <input type="checkbox"/> Dusty <input type="checkbox"/> Astro Turf <input type="checkbox"/> Med Bite <input type="checkbox"/> Other _____		

Front Suspension

Toe: _____

Ride Height: _____

Camber: _____

Caster: 0° 3° 5° 10°

Kick Angle: 20° 25° 30°

Sway Bar: _____

Oil: _____

Piston: _____

Spring: _____

Spindle Type: Inline Trailing

Shock Limiters: _____

Shock Location: _____

Bump Steer: _____

Camber Link: _____

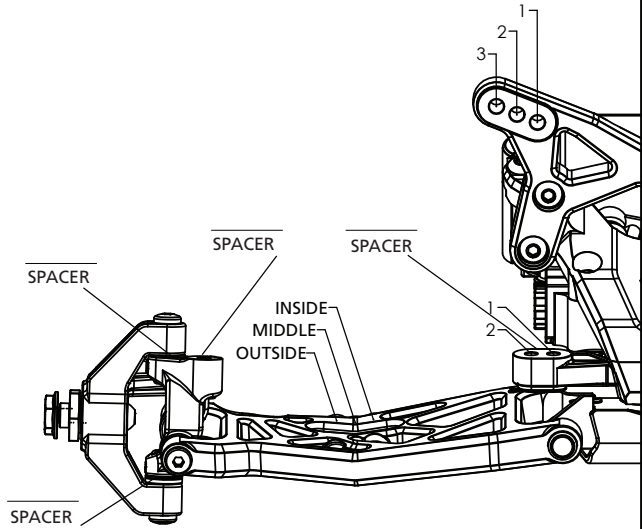

Notes: _____

Rear Suspension

Chassis Configuration: Rear Motor Mid Motor

Toe: _____

Anti-Squat: _____

Roll Center: Low Roll Center (LRC) High Roll Center (HRC)

Ride Height: _____

Camber: _____

Rear Hub Spacing: _____

Hex Width: _____

Sway Bar: _____

Oil: _____

Piston: _____

Spring: _____

Shock Limiters: _____

Camber Link: _____

Shock Locations: _____

Wing/Wickerbill: _____

Battery Position: _____

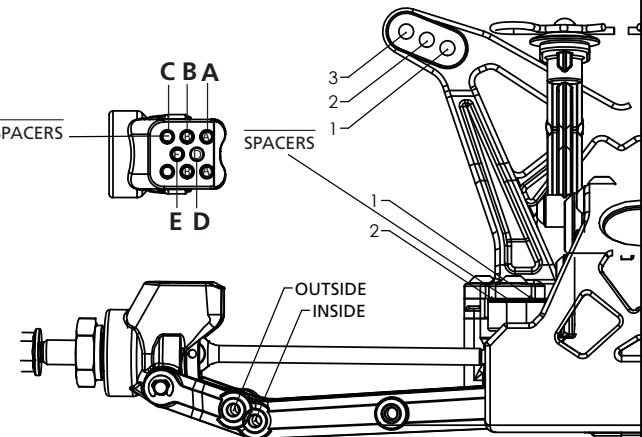

Electronics

Radio: _____

Servo: _____

ESC: _____

Initial Brake: _____

Drag Brake: _____

Throttle Profile: _____

Timing Advance: _____

Throttle/Brake Expo: _____

Servo Expo: _____

Throttle/Brake EPA: _____

Motor: _____

Pinion: _____ Spur: _____

Battery: _____

Weight Placement (Mark with "X")  Weight of each piece _____ oz./g	Tires Front: _____ Rear: _____ Notes: _____	Compound _____	Insert _____	Additive _____
--	--	----------------	--------------	----------------